



HYDRAULIC
Power Unit

5 Ton
56091
4451 (Bluebird)
Parts sheet

May 2021

Product Information

OPERATING INSTRUCTIONS

PROPER USE

1. Center the cap under the load.
2. Wherever possible have the jack lift in a perpendicular position. Lifting at an angle will place an excessive side strain on the ram.
3. Do not push the load off the jack.
4. Always use axle stands when making under vehicle repairs.

A. TO OPERATE

1. Open release valve and pump handle several times. This will eliminate any airbound condition that may have occurred during shipment.
2. Engage the slotted end of the handle with the head of the release screw.
3. Close release valve by turning to right.
4. Insert handle in handle socket and operate the pump.

B. IF JACK WILL NOT OPERATE

1. Release valve may be open— Turn to right to close.
2. No oil in reservoir—with jack in closed position, place in upright position and add hydraulic jack oil through filler plug until oil is level with filler hole. **DO NOT USE ALCOHOL, GLYCERINE, BRAKE FLUID, THICK OR DIRTY OIL.**
3. Intake and pressure valves may be held open by foreign matter— Use operating instructions A-1.
4. Jack will not operate on side —jack may have been placed on wrong side. The side to which the handle socket is attached must be down.
5. Too much oil in the reservoir—Too much oil is liable to cause a vacuum bound jack. The oil should be brought to the level of the fill plug.

C. IF JACK WILL RAISE TO LOAD BUT WILL NOT LIFT IT

1. Release screw may be closed tight enough to raise ram, but not closed tight enough to lift load.
2. Ram may be at extended height—Shim jack up.
3. Ram cup may have become injured or porous, allowing oil to pass it.
4. Air under ram— When there is a quantity of air under the ram, the ram will raise until it hits the load, then it will stay there until there has been sufficient number of pump strokes to compress this air to the proper pressure to lift the load. If this happens, turn jack upside down with ram extended, open release screw and close jack completely. This will cause air to return to oil reservoir.

5. Sticky valves— Empty all oil from reservoir and refill with gasoline or naphtha. Flush as recommended in operating instruction A-1. Then fill with new hydraulic jack oil.

D. IF JACK WILL NOT HOLD LOAD

1. Release valve may not be tight enough.
2. Ram cup may have become injured, allowing oil to pass it.
3. Ball valves may not be seated properly—Flush off as prescribed in operating instructions A-1. The construction of this jack makes the ball valves readily accessible for cleaning. Remove release screw. Remove valves by tipping the jack forward and catching these parts in the hand or a container, place jack on back side with label up to avoid loss of oil. After washing ball valves in kerosene, assemble in reverse order, replace ball if flat spots or pitted surfaces are found.

MAINTENANCE

1. Refill only with recommended jack oil. Never use a substitute.
2. Use every precaution to prevent entrance of dirt when refilling jack.
3. Store in upright position in a dry place.
4. When stored, the ram should be lowered completely. The pump piston should be in the lowest position and the release valve should be closed.
5. Repair kit 5-1104.

LUBRICATION

1. Oil all moving parts periodically.
2. Grease should be used on all exposed parts if jacks are constantly used under wet conditions.

100%
USA
Made

Jack Model 56091 (4451 BlueBird)

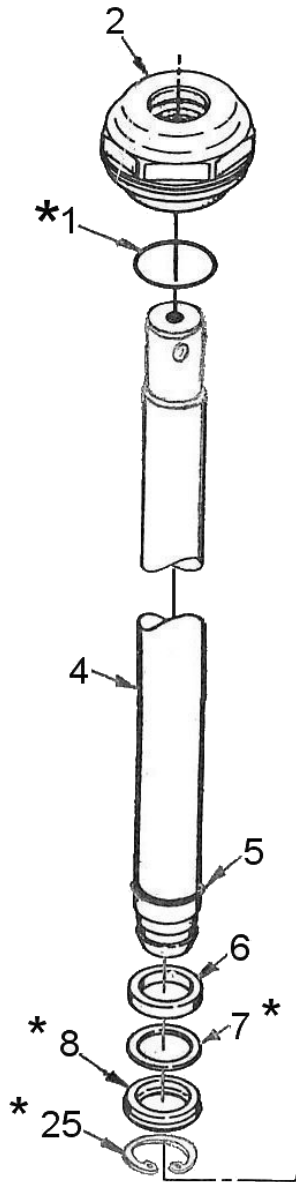

* ITEMS INCLUDED
IN REPAIR KIT
5-1104

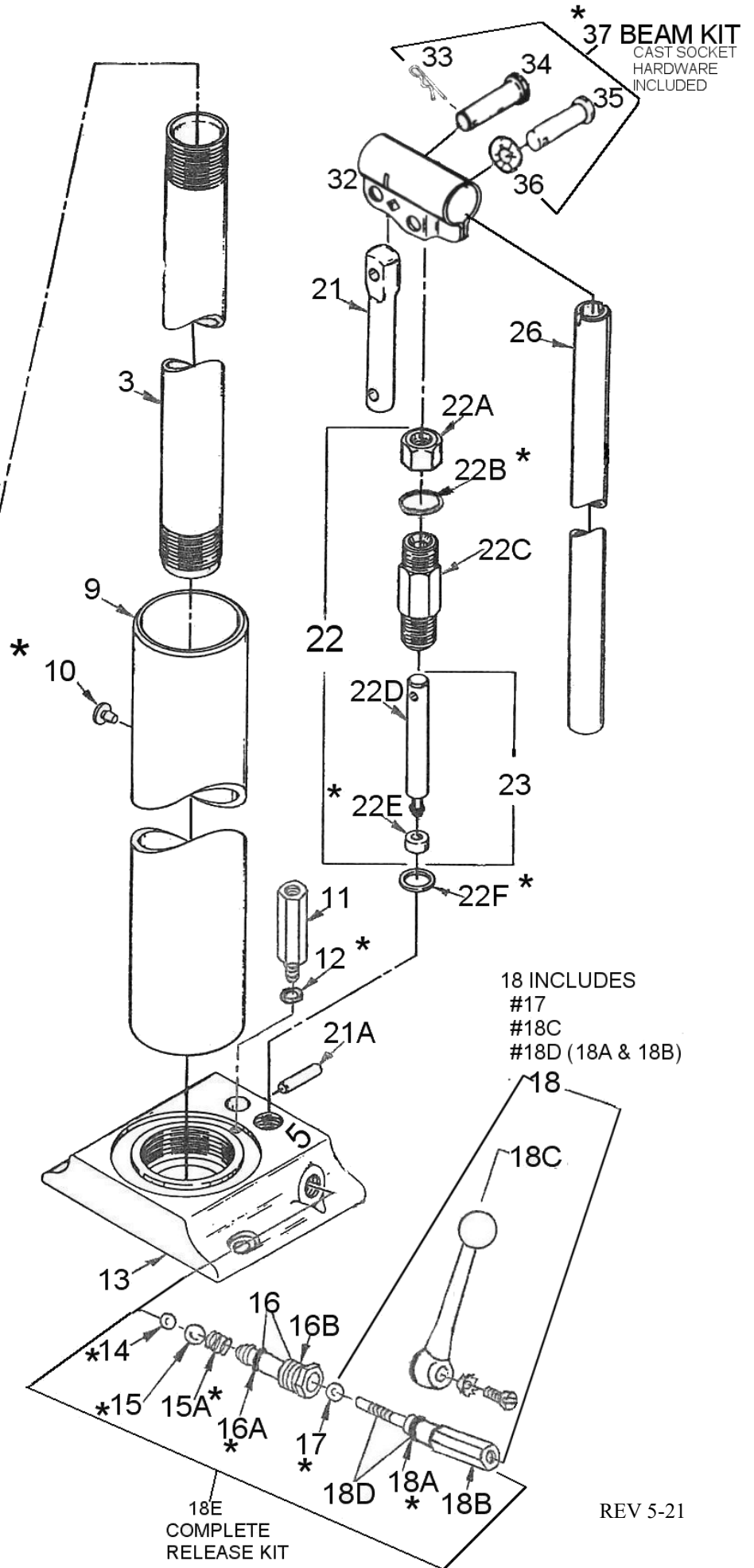

18 INCLUDES
#17
#18C
#18D (18A & 18B)

18E
COMPLETE
RELEASE KIT

ITEM NO	NAME OF PART	5- TON 56091	BLUEBIRD 4451
1 *	"O" Ring 1 3/4 O.D.	D-2099-25	4418
2	Top Cap Reservoir Head	10-11770	4419
3	Ram Cylinder	56094	4420
4	Plunger Ram	56095	4422
5	Ring Up Stop	2-59964	4423
6	Spacer Ring, Cup Support	D-2635-A	4424
7 *	Spacer, Plunger Cup Back-Up	2-58611-3	4425
8 *	Plunger Cup	2-58350-3	4426
9	Reservoir	56093	4427
10 *	Filler Plug, Reservoir	2-54029	4328
11	Safety Valve Assembly	56096	4416
12 *	Gasket, Safety Valve	56069	6047
13	Base	56092	4429
14 *	Ball 7/32	D-2074	6049
15 *	Ball 5/16"	D-2070	6048
15A *	Spring Valve	2-53476	4359
16	Release Insert Assembly	4-58462	4330
16A *	"O" Ring 7/16 O.D.	D-2099-6	4331
16B	Release Insert Housing	2-58436	4332
17 *	Ball 3/16"	10-12399	4333
18	Release Valve and Handle Lever	56227	4334
18A *	"O" Ring 3/8" O.D.	D-2099-5	4337
18B	Release Valve Spindle	56061	4336
18C	Release Valve Lever Kit	56218	6055
18D	Release Spindle Assembly	56274	NONE
18E	Complete Release Kit	56337	NONE
21	Link Kit Includes 21A	56217	4340
21A	Pin Link	D-2848-A	4317
22	Pump Unit Assembly	56573	4341
22A	Nut, Pump Packing	10-11740	4342
22B *	"O" Ring 11/16" O.D.	D-2099-10	4343
22C	Cylinder Pump	D-2044-A	4344
22D	Plunger, Pump	56271	4345
22E *	Plunger Cup Pump	56272	4346/6039C
22F *	Gasket, Pump	D-2027	4347
23	Pump Plunger Assembly	56273	4348
25 *	Plunger Cup Retainer Clip	56250	NONE
26	Pump Handle – 20" Handle	10-12020	NONE
32	Handle Socket	10-11755	NONE
33*	Retaining Clip	2-58541	NONE
34*	Handle Socket Link Pin	10-12019	NONE
35*	Handle Socket Link Pin	CH-1028	NONE
36 *	Retaining Ring	10-11758	NONE
37 *	Beam Kit (incl. socket hardware)	56216	NONE
	REPAIR KIT	5-1104	4452

WARRANTY INFORMATION:

All U.S. Jack manufactured products are warranted for a period of one year against defects in material and workmanship. This warranty is limited to the original consumer purchaser. Warranty does not cover damage due to accident, neglect, or misuse, or products that have been altered or modified, or to which attachments not recommended by the manufacturer have been added. Proof of purchase is required and all warranty claims should be submitted directly to U.S. JACK COMPANY.

WARNING

- A. THIS DEVICE IS A LIFTING DEVICE ONLY. THE LOAD SHALL BE SUPPORTED IMMEDIATELY BY OTHER APPROPRIATE MEANS.**
- B. DO NOT OVERLOAD. OVERLOADING CAN CAUSE DAMAGE TO OR FAILURE OF THE JACK.**
- C. LIFT ONLY ON AREAS OF THE VEHICLE AS SPECIFIED BY THE VEHICLE MANUFACTURER.**
- D. THIS JACK DESIGNED FOR USE ONLY ON HARD, LEVEL SURFACES CAPABLE OF SUSTAINING THE LOAD. USE ON OTHER THAN HARD, LEVEL SURFACES CAN RESULT IN JACK INSTABILITY AND POSSIBLE LOSS OF LOAD.**
- E. FAILURE TO HEED THESE WARNINGS MAY RESULT IN LOSS OF LOAD, DAMAGE TO THE JACK, AND/OR FAILURE RESULTING IN PERSONAL INJURY OR PROPERTY DAMAGE.**

U.S. Jack and American Pride

1125 Industrial Court Benton Harbor MI 49022
Mailing Address P.O. Box 8826 Benton Harbor MI 49023
PH 269-925-7777 Fax 269-925-6656

Visit our Website: www.usjack.com