



HYDRAULIC
POWER UNIT

PRODUCT INFORMATION

5-TON LONG RAM
HYD. JACK
MODEL #: 56100-C
PARTS SHEET

OPERATING INSTRUCTIONS

JUNE 2019

PROPER USE

1. Center the cap under the load.
2. Wherever possible have the jack lift in a perpendicular position. Lifting at an angle will place an excessive side strain on the ram.
3. Do not push the load off the jack.
4. Always use axle stands when making under vehicle repairs.

A. TO OPERATE

1. Open release valve and pump handle several times. This will eliminate any airbound condition that may have occurred during shipment.
2. Engage the slotted end of the handle with the head of the release screw.
3. Close release valve by turning to right.
4. Insert handle in handle socket and operate the pump.

B. IF JACK WILL NOT OPERATE

1. Release valve may be open— Turn to right to close.
2. No oil in reservoir—with jack in closed position, place in upright position and add hydraulic jack oil through filler plug until oil is level with filler hole. **DO NOT USE ALCOHOL, GLYCERINE, BRAKE FLUID, THICK OR DIRTY OIL.**
3. Intake and pressure valves may be held open by foreign matter— Use operating instructions A-1.
4. Jack will not operate on side —jack may have been placed on wrong side. The side to which the handle socket is attached must be down.
5. Too much oil in the reservoir—Too much oil is liable to cause a vacuum bound jack. The oil should be brought to the level of the fill plug.

C. IF JACK WILL RAISE TO LOAD BUT WILL NOT LIFT IT

1. Release screw may be closed tight enough to raise ram, but not closed tight enough to lift load.
2. Ram may be at extended height—Shim jack up.
3. Ram cup may have become injured or porous, allowing oil to pass it.
4. Air under ram— When there is a quantity of air under the ram, the ram will raise until it hits the load, then it will stay there until there has been sufficient number of pump strokes to compress this air to the proper pressure to lift the load. If this happens, turn jack upside down with ram extended, open release screw and close jack completely. This will cause air to return to oil reservoir.

5. Sticky valves— Empty all oil from reservoir and refill with gasoline or naphtha. Flush as recommended in operating instruction A-1. Then fill with new hydraulic jack oil.

D. IF JACK WILL NOT HOLD LOAD

1. Release valve may not be tight enough.
2. Ram cup may have become injured, allowing oil to pass it.
3. Ball valves may not be seated properly—Flush off as prescribed in operating instructions A-1. The construction of this jack makes the ball valves readily accessible for cleaning. Remove release screw. Remove valves by tipping the jack forward and catching these parts in the hand or a container, place jack on back side with label up to avoid loss of oil. After washing ball valves in kerosene, assemble in reverse order, replace ball if flat spots or pitted surfaces are found.

MAINTENANCE

1. Refill only with recommended jack oil. Never use a substitute.
2. Use every precaution to prevent entrance of dirt when refilling jack.
3. Store in upright position in a dry place.
4. When stored, the ram should be lowered completely. The pump piston should be in the lowest position and the release valve should be closed.
5. Repair kit 5-1104.

LUBRICATION

1. Oil all moving parts periodically.
2. Grease should be used on all exposed parts if jacks are constantly used under wet conditions.

100%
USA
Made

56100-C 5-Ton Long Ram Hyd. Jack/ Power Unit

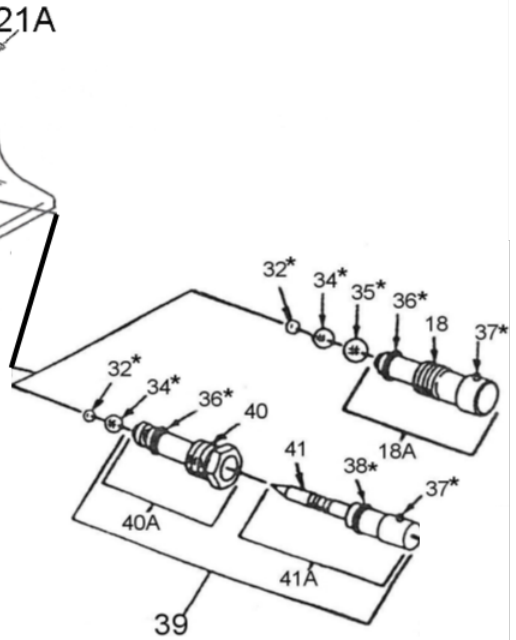
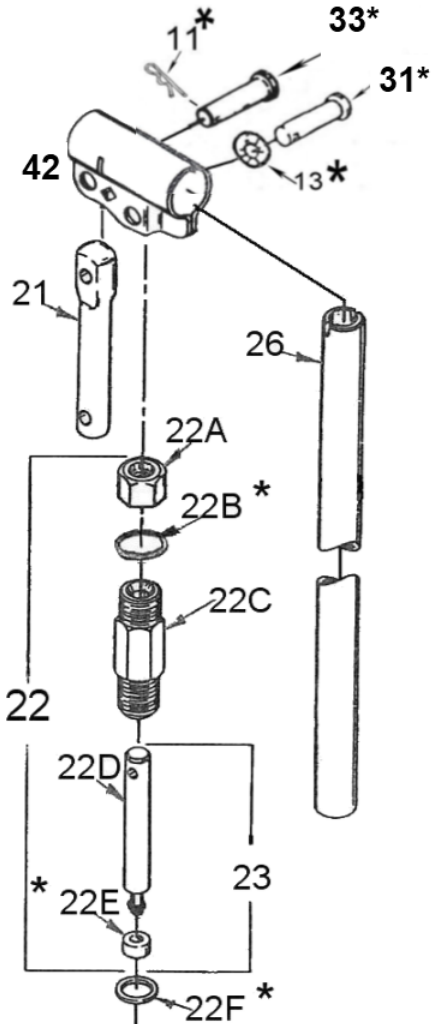
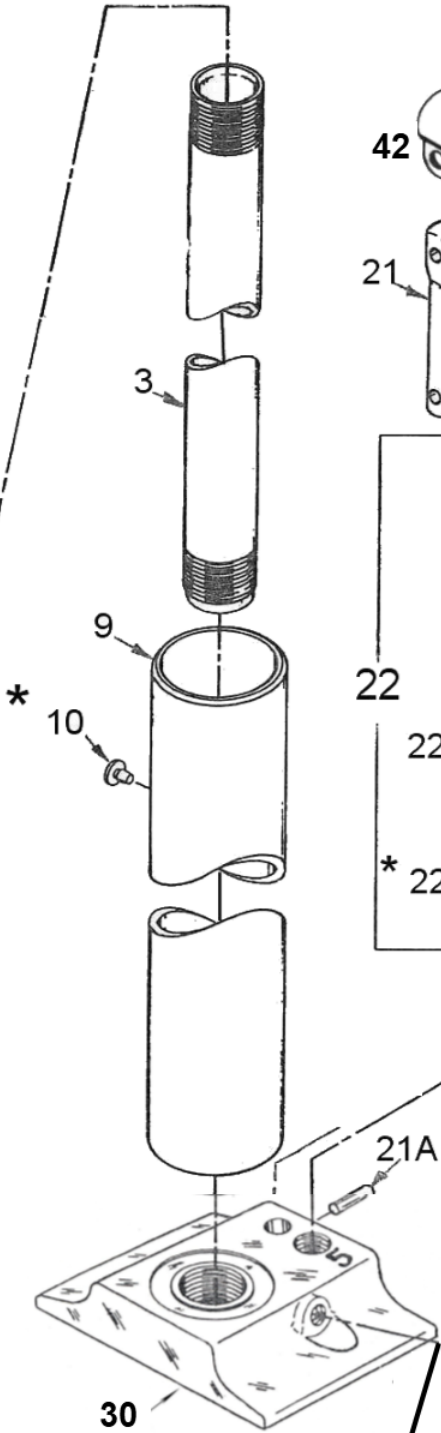
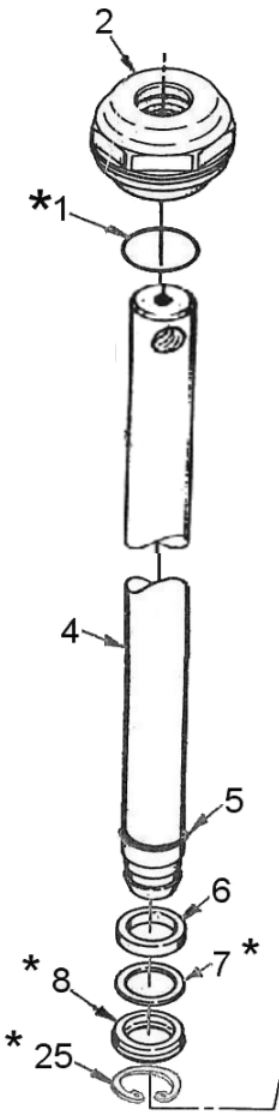

ITEM NO	NAME OF PART	5- TON 56100-C
1*	"O" Ring 1 ¼ O.D.	D-2099-25
2	Top Cap Reservoir Head	10-11770
3	Ram Cylinder	56102
4	Plunger Ram	56103
5	Ring Up Stop	2-59964
6	Spacer Ring, Cup Support	D-2635-A
7*	Spacer, Plunger Cup Back-Up	2-58611-3
8*	Plunger Cup	2-58350-3
9	Reservoir	56104
10*	Filler Plug, Reservoir	2-54029
11*	Retaining Clip	2-58541
13*	Retaining Ring	10-11758
18	Single Piece Release Screw	2-50418
18A	Release Screw Assembly	4-50514
21	Handle Socket Piston Link	D-2547
21A	Pin Link	D-2848-A
22	Pump Unit Assembly	56573
22A	Nut, Pump Packing	10-11740
22B*	"O" Ring 1 1/16" O.D.	D-2099-10
22C	Cylinder Pump	D-2044-A
22D	Plunger, Pump	56271
22E*	Plunger Cup Pump	56272
22F*	Gasket, Pump	D-2027
23	Pump Plunger Assembly	56273
25*	Plunger Cup Retainer Clip	56250
26	Pump Handle – 20" Handle	10-12020
30	Base	D-2601-C
31*	Handle Socket Link Pin	CH-1028
32*	Ball 3/16"	10-12399
33*	Handle Socket Link Pin	10-12019
34*	Ball 7/32	D-2074
35*	Ball 5/16"	D-2070
36*	"O" Ring 7/16 O.D.	D-2099-6
37*	Release Screw Pin	2-58745
38*	"O" Ring 3/8" O.D.	D-2099-5
39	Release Screw Assembly	4-58754
40	Release Insert	2-58436
40A	Release Insert Sub-Assembly	4-58462
41	2-PC Release Screw	2-58437
41A	2-PC Release Screw Sub-Assembly	4-58460
42	Handle Socket	10-11755
	REPAIR KIT	5-1102

WARRANTY INFORMATION:

All U.S. Jack manufactured products are warranted for a period of one year against defects in material and workmanship. This warranty is limited to the original consumer purchaser. Warranty does not cover damage due to accident, neglect, or misuse, or products that have been altered or modified, or to which attachments not recommended by the manufacturer have been added. Proof of purchase is required and all warranty claims should be submitted directly to U.S. JACK COMPANY.

WARNING

- A. THIS DEVICE IS A LIFTING DEVICE ONLY. THE LOAD SHALL BE SUPPORTED IMMEDIATELY BY OTHER APPROPRIATE MEANS.**
- B. DO NOT OVERLOAD. OVERLOADING CAN CAUSE DAMAGE TO OR FAILURE OF THE JACK.**
- C. LIFT ONLY ON AREAS OF THE VEHICLE AS SPECIFIED BY THE VEHICLE MANUFACTURER.**
- D. THIS JACK DESIGNED FOR USE ONLY ON HARD, LEVEL SURFACES CAPABLE OF SUSTAINING THE LOAD. USE ON OTHER THAN HARD, LEVEL SURFACES CAN RESULT IN JACK INSTABILITY AND POSSIBLE LOSS OF LOAD.**
- E. FAILURE TO HEED THESE WARNINGS MAY RESULT IN LOSS OF LOAD, DAMAGE TO THE JACK, AND/OR FAILURE RESULTING IN PERSONAL INJURY OR PROPERTY DAMAGE.**

U.S. Jack and American Pride

1125 Industrial Court Benton Harbor MI 49022
Mailing Address P.O. Box 8826 Benton Harbor MI 49023
PH 269-925-7777 Fax 269-925-6656

Visit our Website: www.usjack.com