



PRODUCT INFORMATION

30 TON
Portable Hydraulic Jack
D-51127
PARTS SHEET
56553

August 2021

OPERATING INSTRUCTIONS

Proper Use

1. When lifting on load rest be sure that load is centered and that lift is perpendicular. Lifting on an angle places excessive side strain on ram.
2. Do not push the load off the jack.
3. Always use axle stands when making under-vehicle repairs.

A To Operate

1. Open release valve and pump handle several times. This will eliminate any airbound condition that may have occurred during shipment.
2. Engage the slotted end of the handle with the head of the release screw.
3. Close release valve by turning to right.
4. Insert handle in handle socket and operate the pump.

B If Jack Will Not Operate

1. Release valve may be open— Turn to right to close.
2. No oil in reservoir — with jack in closed position, place in upright position and add Hydraulic Jack Oil through filler plug until oil is level with filler hole. **DO NOT USE ALCOHOL, GLYCERINE, BRAKE FLUID, THICK OR DIRTY OIL.**
3. Intake and pressure valves may be held open by foreign matter —Use operating instructions A-1
4. Jack will not operate on side — Jack may have been placed on wrong side. The side to which the handle socket is attached must be down.
5. Too much oil in the reservoir —Too much oil is liable to cause a vacuum bound jack. The oil should be brought to the level of the filler plug.

C If Jack Will Raise To Load But Will Not Lift It

1. Release screw may be closed tight enough to raise ram, but not closed tight enough to lift load.
2. Ram may be at extended height— Shim jack up.
3. Ram cup may have become injured or porous, allowing oil to pass it.

4. Air under ram —When there is a quantity of air under the ram, the ram will raise until it hits the load, then it will stay there until there has been sufficient number of pump strokes to compress this air to the proper pressure to lift the load. If this happens, turn jack upside down with ram extended, open release screw and close jack completely. This will cause air to return to oil reservoir.
5. Sticky valves — Empty all oil from reservoir and refill with gasoline or naphtha. Flush as recommended in operating instruction A-1 . Then fill with new Hydraulic Jack Oil.

D If Jack Will Not Hold Load

1. Release valve may not be tight enough.
2. Ram cup may have become injured, allowing oil to pass it.
3. Ball valves may not be seated properly—Flush off as prescribed in operating instruction A-1. The construction of this jack makes the ball valves readily accessible for cleaning. Remove release screw. Remove valves by tipping the jack forward and catching these parts in the hand or a container, place jack on back side with label up to avoid loss of oil. After washing ball valves in kerosene, assemble in reverse order. Replace ball if flat spots or pitted surfaces are found.

E Maintenance

1. Refill only with recommended Jack Oil. Never use a substitute.
2. Use every precaution to prevent entrance of dirt when refilling jack
3. Store in upright position in a dry place
4. When stored, the ram should be lowered completely. The pump piston should be in the lowest position and the release valve should be closed.
5. Repair Kit # 5-553

F Lubrication

1. Oil all moving parts periodically
2. Grease should be used on all exposed parts if jacks are constantly used under wet conditions.

100% USA MADE

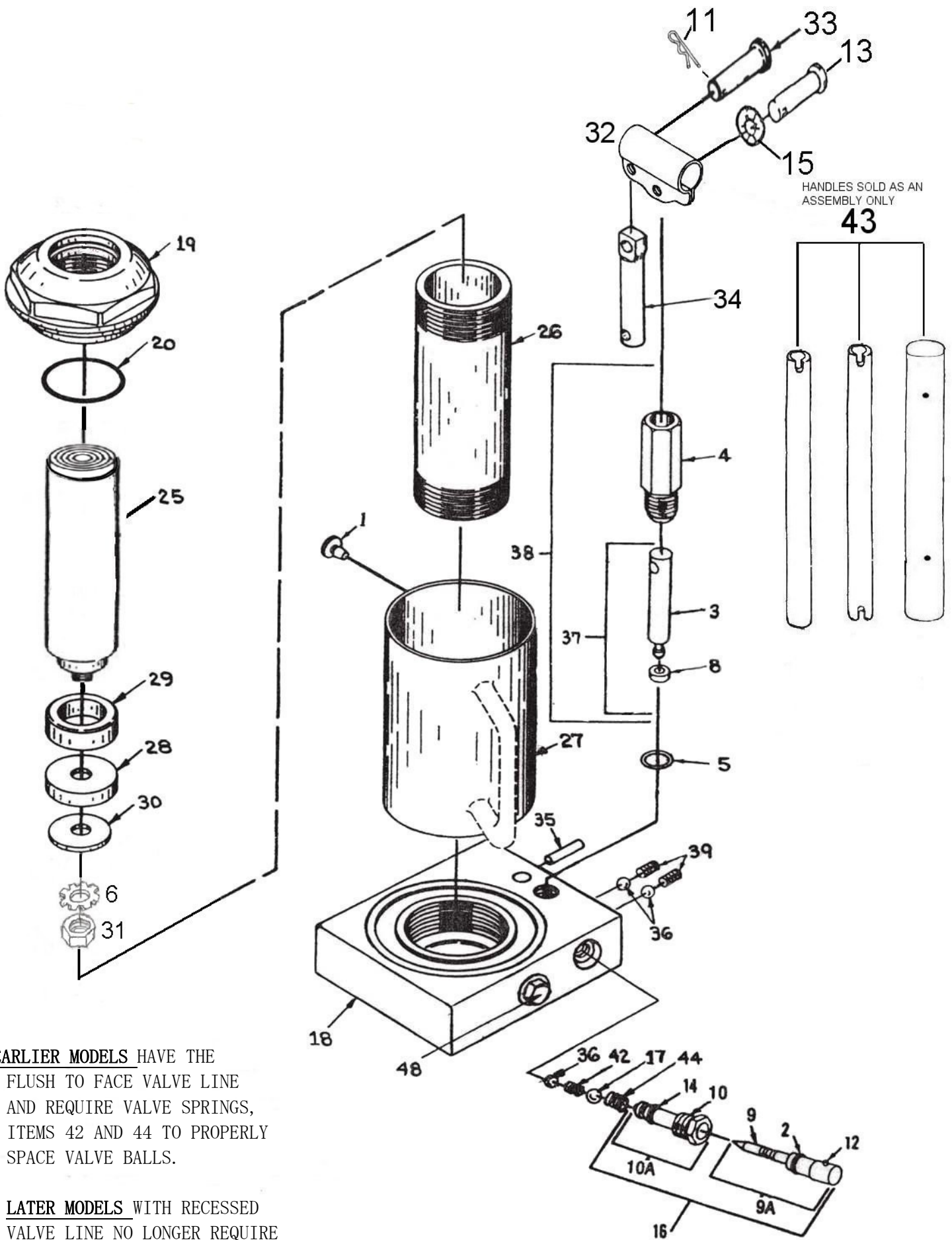

NOTE: EARLIER MODELS HAVE THE FLUSH TO FACE VALVE LINE AND REQUIRE VALVE SPRINGS, ITEMS 42 AND 44 TO PROPERLY SPACE VALVE BALLS.

LATER MODELS WITH RECESSED VALVE LINE NO LONGER REQUIRE THESE ITEMS

ITEM NO.	NAME OF PART	30 TON D-51127
1	Filler Plug *	2-54029
2	"O" Ring (1/4 x 3/8)*	D-2099-5
3	Pump Piston	2-54945
4	Pump Cylinder	2-50423
5	Piston Pump Washer *	D-2027
6	Lock Washer	56466
8	Piston Cup *	10-11760
9	Release Screw	2-58437
9A	Release Screw Sub Assembly	4-58460
10	Release Insert	2-58436
10A	Release Insert Sub Assembly	4-58462
11	Hitch Pin Clip *	2-58541
12	Release Screw	2-58745
13	Handle Socket Link Pin *	CH-1028
14	"O" Ring (5/16 x 7/16) *	D-2099-6
15	Retaining Ring *	10-11758
16	Release Screw Assembly	4-58754
17	Valve Ball (5/16 dia) *	D-2070
18	Base	2-59469
19	Reservoir Head	D-3202
20	"O" Ring *	D-2099-33
25	Ram	D-3205
26	Ram Cylinder	D-3213
27	Reservoir	4-59483
28	Ram Cup *	D-3234
29	Ram Spacer	D-3235-A
30	Ram Cup Retainer	D-3236
31	Ram Cup Nut	56467
32	Handle Socket	10-11755
33	Handle Socket Link Pin *	10-12019
34	Link Piston	D-2547
35	Link Pin	D-2848-A
36	Valve Ball (7/32 Dia. -3) *	D-2074
37	Piston Assembly	4-54947
38	Pump Assembly	4-50518
39	Side Ball Plug *	2-53710
42	Intake Ball Spring *	2-53475
43	Handle Assembly 3 PC	56340
44	Pressure Ball Spring *	2-53476
48	Gauge Port Plug Assembly	2-58951
	Repair Kit	5-553

* Denotes Items in repair kits

WARRANTY INFORMATION:

All U.S. Jack manufactured products are warranted for a period of one year against defects in material and workmanship. This warranty is limited to the original consumer purchaser. Warranty does not cover damage due to accident, neglect, or misuse, or products that have been altered or modified, or to which attachments not recommended by the manufacturer have been added. Proof of purchase is required and all warranty claims should be submitted directly to U.S. JACK COMPANY.

WARNING

- A. THIS DEVICE IS A LIFTING DEVICE ONLY. THE LOAD SHALL BE SUPPORTED IMMEDIATELY BY OTHER APPROPRIATE MEANS.**
- B. DO NOT OVERLOAD. OVERLOADING CAN CAUSE DAMAGE TO OR FAILURE OF THE JACK.**
- C. LIFT ONLY ON AREAS OF THE VEHICLE AS SPECIFIED BY THE VEHICLE MANUFACTURER.**
- D. THIS JACK DESIGNED FOR USE ONLY ON HARD, LEVEL SURFACES CAPABLE OF SUSTAINING THE LOAD. USE ON OTHER THAN HARD, LEVEL SURFACES CAN RESULT IN JACK INSTABILITY AND POSSIBLE LOSS OF LOAD.**
- E. FAILURE TO HEED THESE WARNINGS MAY RESULT IN LOSS OF LOAD, DAMAGE TO THE JACK, AND/OR FAILURE RESULTING IN PERSONAL INJURY OR PROPERTY DAMAGE.**

U.S. Jack and American Pride

1125 Industrial Court, Benton Harbor MI 49022
Mailing Address P.O. Box 8826 Benton Harbor MI 49023
PH 269-925-7777 Fax 269-925-6656

Visit our Website: www.usjack.com
Email: sales@usjack.com